

PAST PSSH SHOOTHOUSE- FOR EXISTING BUILDINGS

ITEM NO.	PART NUMBER	QTY.	DESCRIPTION
1	AP-01850	5	2FT. WALL PANEL 95.625
2	AP-01851	13	4FT. WALL PANEL 95.625
3	AP-01852	16	DOOR PANEL 4 FT. X 95.625 LEFT

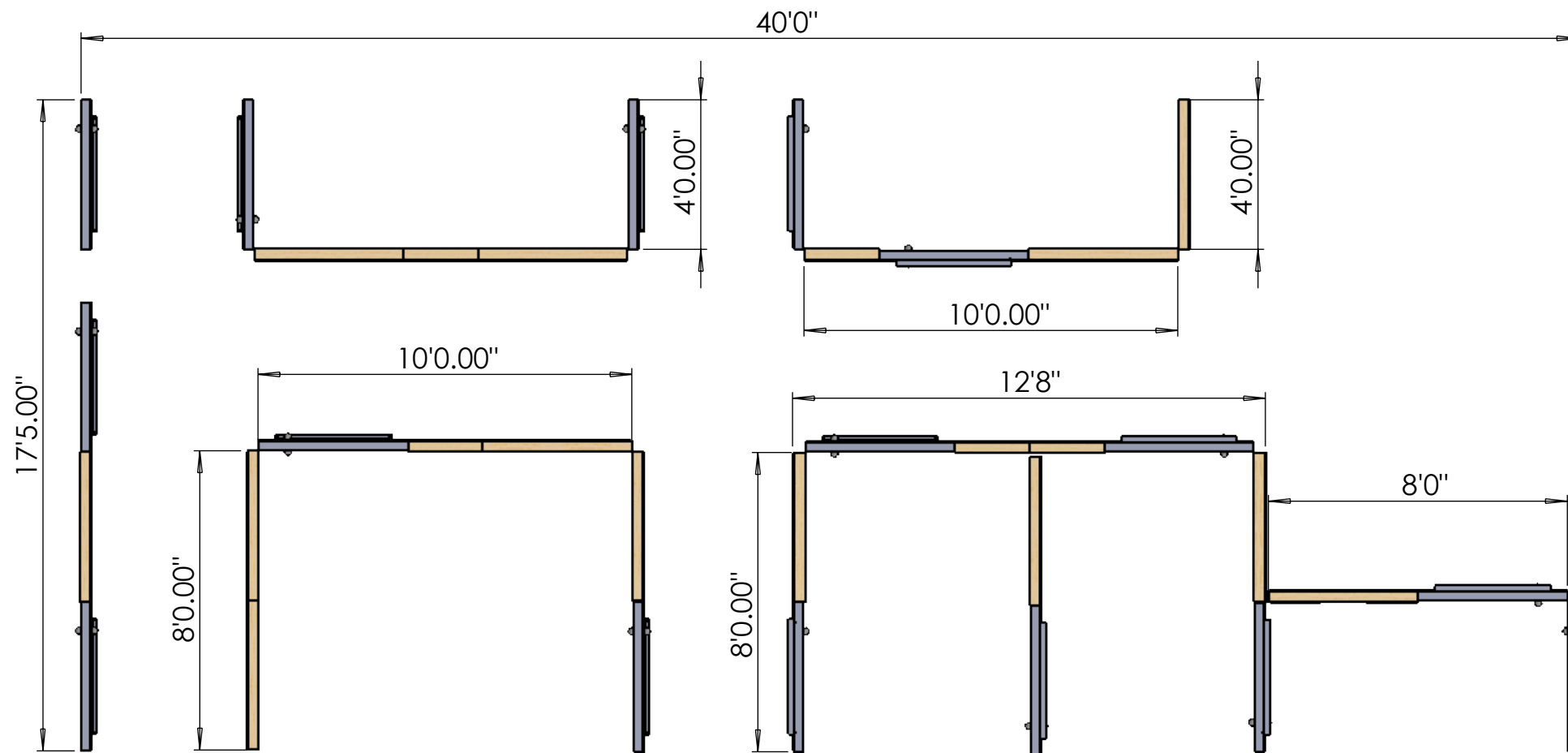

*DOOR AND TYPICAL PANELS ARE 4' WIDE
2' WIDE PANELS ARE ALSO USED DEPENDING
ON LAYOUT

CUSTOM PANELS CAN BE MADE FOR EXISTING
BUILDINGS

DOOR PANELS CAN BE CONFIGURED TO OPEN
LEFT OR RIGHT; INSIDE AND OUTSIDE

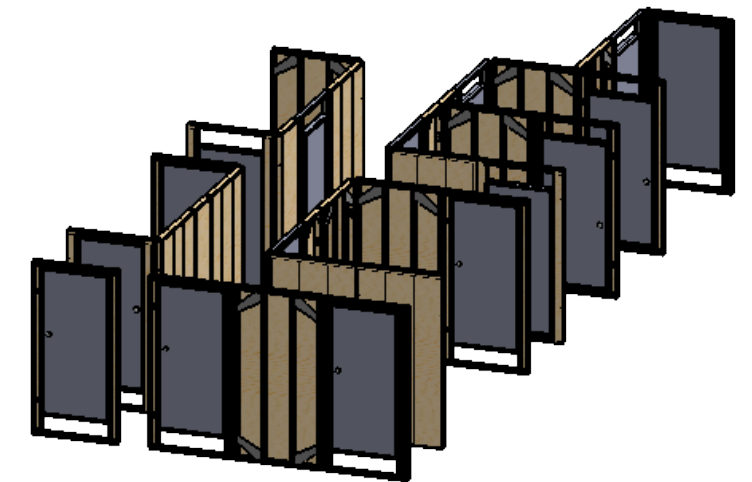

INITIALS	DATE	<h2>MGM TARGETS</h2> <p>MIKE GIBSON MANUFACTURING www.mgmtargets.com (208) 454-0555 or (888) 767-7371</p> <p><small>PROPRIETARY AND CONFIDENTIAL THE INFORMATION CONTAINED IN THIS DRAWING IS THE SOLE PROPERTY OF MIKE GIBSON MANUFACTURING. ANY REPRODUCTION IN PART OR AS A WHOLE WITHOUT THE WRITTEN PERMISSION OF MIKE GIBSON MANUFACTURING IS PROHIBITED.</small></p> <p><small>UNLESS OTHERWISE SPECIFIED DIMENSIONS ARE IN INCHES TOLERANCES: FRACTIONAL ± 1/16 ANGULAR: MACH ± .5 BEND ± 1 TWO PLACE DECIMAL ± .020 THREE PLACE DECIMAL ± .005 DO NOT SCALE DRAWING</small></p>	DESCRIPTION: PORTABLE SIMUNITIONS SHOOT HOUSE, PAST DESIGN EXAMPLE, EXISTING BUILDING	
DRWN BY: ---	XXXX/XX		PART NO:	
CHK'D BY: ---	XXXX/XX		JIG NO:	REV:
ENG APPR: ---	XXXX/XX		SHEET 2 OF 2	
MFG APPR: ---	XXXX/XX		-	
MATERIAL:				
MATERIAL SIZE:				
THICKNESS:	WEIGHT:			