

TOP VIEW

ITEM NO.	PART NUMBER	QTY.	DESCRIPTION
1	AP-01850	5	2FT. WALL PANEL 95.625
2	AP-01851	58	4FT. WALL PANEL 95.625
3	AP-01852	5	DOOR PANEL 4 FT. X 95.625 RIGHT
4	AP-01955	1	CUSTOM WALL PANEL, 46-1/8" X 95-5/8"
5	AP-01956	1	CUSTOM WALL PANEL, 18-3/16"
6	CP-02878	11	A SHORT 6FT. FORM ANGLE 3.88X 3.88
7	CP-02879	4	A MED. 7'-10" FORMED ANGLE
8	CP-02880	8	A LONG 7'-10" FORMED ANGLE
9	AP-01852	7	DOOR PANEL 4 FT. X 95.625 LEFT
10	CP-03130	7	2 x 4 x 10'
11	CP-03130	3	2 x 4 x 8'

*DOOR AND TYPICAL PANELS ARE 4' WIDE
2' WIDE PANELS ARE ALSO USED DEPENDING ON LAYOUT.

DOOR PANELS CAN BE CONFIGURED TO OPEN LEFT OR RIGHT; INSIDE AND OUTSIDE

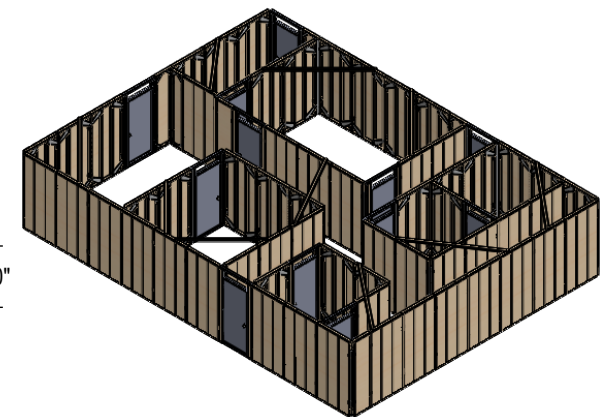

ISOMETRIC VIEW
SCALE 1 : 200

DRWN BY:	INITIALS	DATE
CHK'D BY:	---	XX/XX/XX
ENG APPR:	---	XX/XX/XX
MFG APPR:	---	XX/XX/XX
MATERIAL:		
MATERIAL SIZE:		
THICKNESS:	WEIGHT:	

MGM TARGETS
 MIKE GIBSON MANUFACTURING
 www.mgmtargets.com +1 (208) 454-0555 or +1 (888) 767-7371

PROPRIETARY AND CONFIDENTIAL
 THE INFORMATION CONTAINED IN THIS DRAWING IS THE SOLE PROPERTY OF MIKE GIBSON MANUFACTURING. ANY REPRODUCTION IN PART OR AS A WHOLE WITHOUT THE WRITTEN PERMISSION OF MIKE GIBSON MANUFACTURING IS PROHIBITED.

UNLESS OTHERWISE SPECIFIED DIMENSIONS ARE IN INCHES
 TOLERANCES:
 FRACTIONAL ±1/16
 ANGULAR: MACH ±.5 BEND ±1
 TWO PLACE DECIMAL ±.020
 THREE PLACE DECIMAL ±.005
DO NOT SCALE DRAWING

DESCRIPTION: PSSH PROPOSAL COLUMBIA TN PD	
PART NO:	
JIG NO:	REV:
SHEET 1 OF 2	

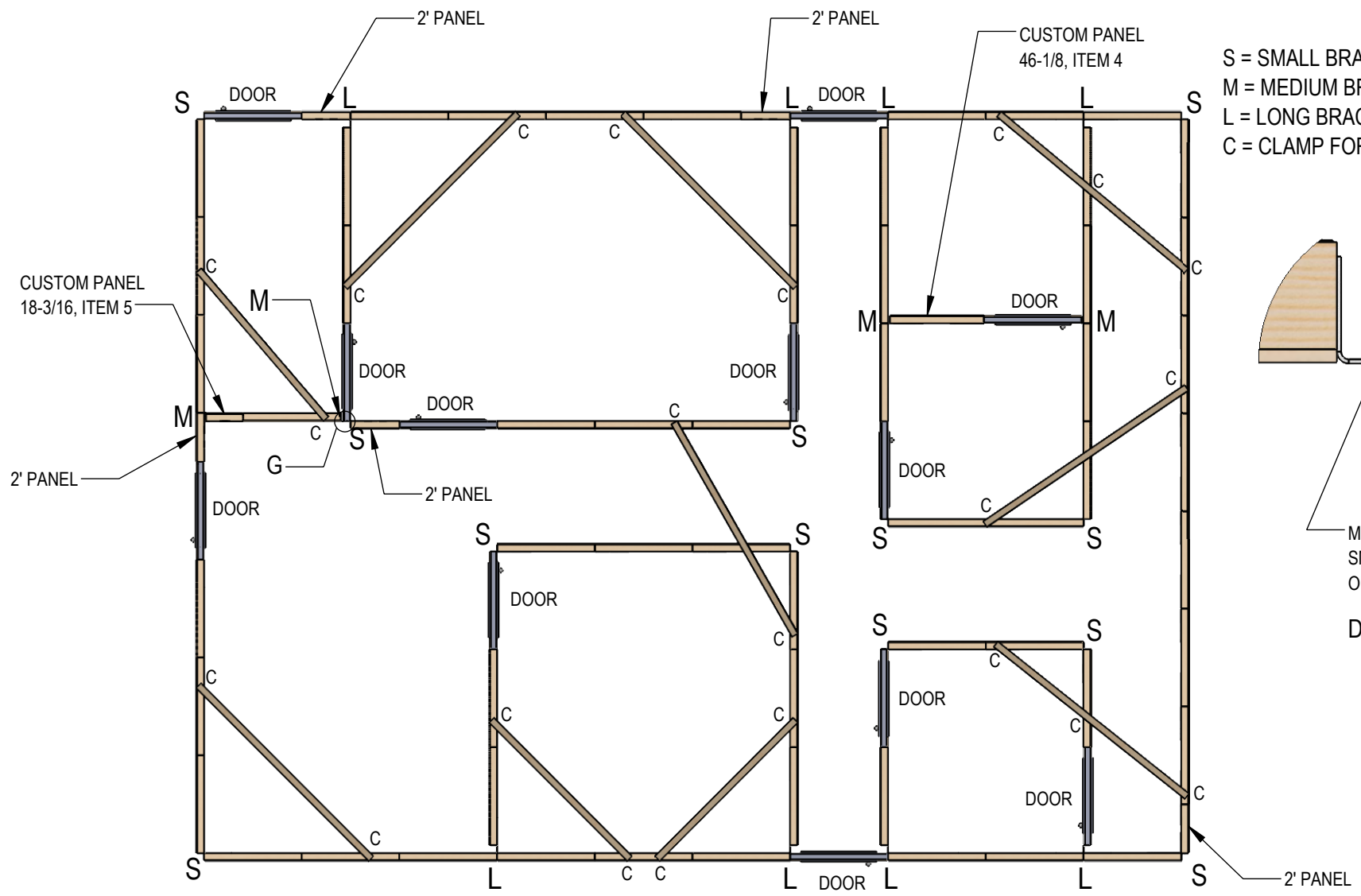

KEY
 S = SMALL BRACKET, CORNERS
 M = MEDIUM BRACKET, INTERSECTIONS
 L = LONG BRACKET, INTERSECTIONS
 C = CLAMP FOR 2X4 SUPPORT

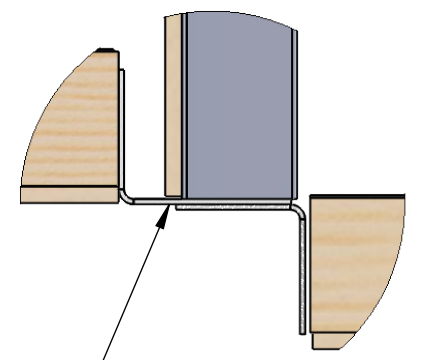

MIDDLE SIZE BRACKET INSIDE,
 SMALL BRACKET OUTSIDE, IN
 ORIENTATION SHOWN
DETAIL G

	INITIALS	DATE
DRWN BY:		
CHK'D BY:	---	XX/XX/XX
ENG APPR:	---	XX/XX/XX
MFG APPR:	---	XX/XX/XX
MATERIAL:		
MATERIAL SIZE:		
THICKNESS:	WEIGHT:	

MGM TARGETS

MIKE GIBSON MANUFACTURING
 www.mgmtargets.com +1 (208) 454-0555 or +1 (888) 767-7371

PROPRIETARY AND CONFIDENTIAL
 THE INFORMATION CONTAINED IN THIS DRAWING IS THE SOLE PROPERTY OF MIKE GIBSON MANUFACTURING. ANY REPRODUCTION IN PART OR AS A WHOLE WITHOUT THE WRITTEN PERMISSION OF MIKE GIBSON MANUFACTURING IS PROHIBITED.

UNLESS OTHERWISE SPECIFIED DIMENSIONS ARE IN INCHES
 TOLERANCES:
 FRACTIONAL ±1/16
 ANGULAR: MACH ±.5 BEND ±1
 TWO PLACE DECIMAL ±.020
 THREE PLACE DECIMAL ±.005
DO NOT SCALE DRAWING

DESCRIPTION: PSSH PROPOSAL COLUMBIA TN PD	
PART NO:	
JIG NO:	REV:
SHEET 2 OF 2	